



RIVCLINCH® (SPOT CLINCH®) 1106 P50 PASS

Multi-purpose, high capacity portable clinching machine

BÖLLHOFF

attexor



Main features

Multi-purpose, high capacity portable clinching machine. One of its unique features is the Passive Approach Stroke System (PASS) which is included. It consists of a separate trigger for the approach stroke, which is run at low force. Once the punch gap is below 8 mm, the second trigger is able to produce the work stroke at high force for the clinching operation. In addition to the safety aspect, the PASS facilitates the positioning of the tool at the clinch joint location prior to trigger the clinching operation. Its design has been optimized for reducing the weight, and for integrating the hydraulic tubing and functions. It is well balanced in all positions by means of a gyroscopic suspension, ball bearing mounted for easy handling.

The rotating axis is placed around the handle and the swivel hydraulic connection, in order to facilitate the work head manipulation with one hand and without effort. The booster and 2 m hose are included.

Technical specifications

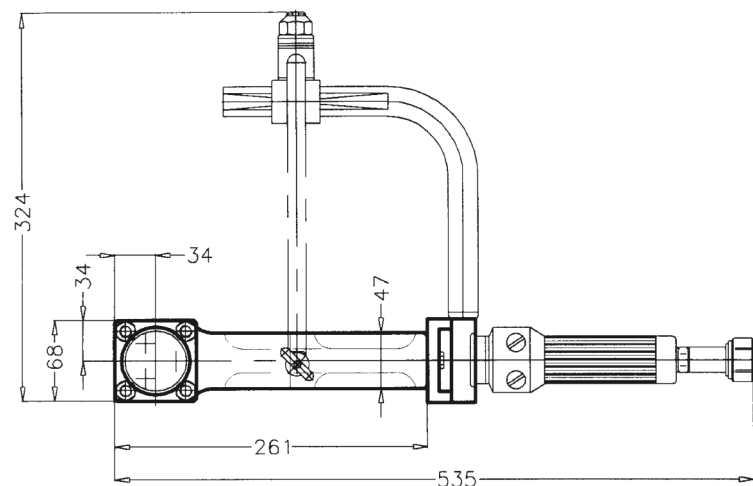
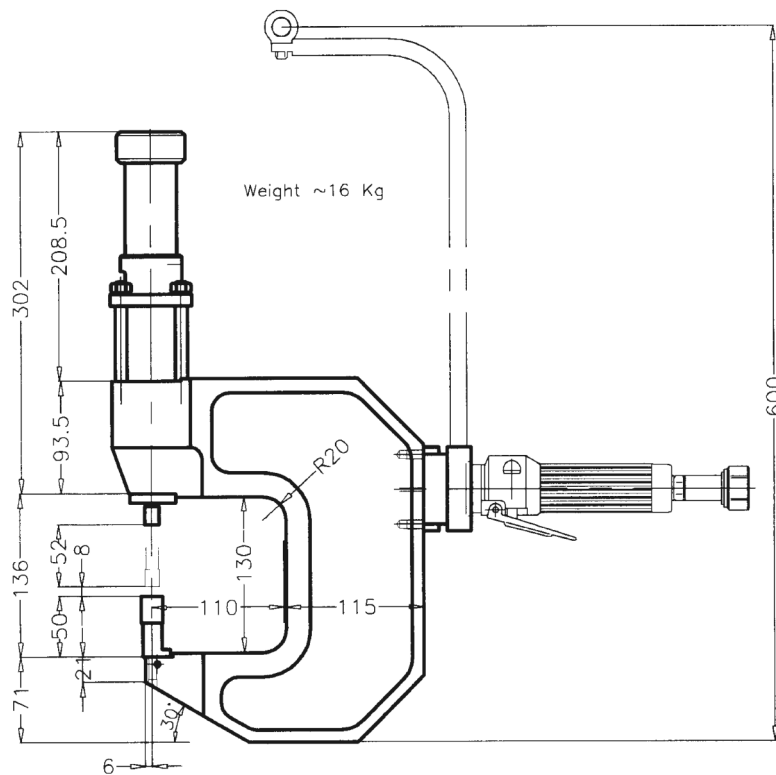

Accessories

- Mechanical stripper (on piston rod). Remark: no need for mechanical stripper on die side, due to the principle of the die)
- Gyroscopic suspension, with rotating bearing between handle and C' frame
- Balancer 14-18 Kg

Tool kits

- Round die Series SRx03, SRx02, Ø 5.0, 6.0, 7.0 mm
- Rectangular die Series STxy2, width 4.3, 5.0 mm
- Die cage protection and elongators

Total weight of the work head, incl. handle and booster	16 kg	35 lbs
Working air pressure	min.	4 bar 58 psi
	max.	6 bar 87 psi
Hydraulic pressure at 6 bar	350 bar	5'000 psi
Max. tool force at 6 bar	50 kN	110 klbs
Max. piston force in approach stroke	50 N	11 Lbs
Work stroke	6.5 mm	0.55"
Approach stroke	52 mm	2.0"
Total stroke	60 mm	2.36"
Cycle time, work stroke	0.9 to 1.5 s	
Max. total sheet thickness, mild steel	4.0 mm	0.16"
Max. total sheet thickness, stainless steel (tool kit ST)	3.0 mm	0.12"



Bollhoff Attexor SA · 6, Chemin des Grandes Pièces - Z.I.B · 1024 Ecublens · Switzerland

Tel. : +41 21 694 80 00 · Fax : +41 21 694 80 01 · Email : sales_bax@bollhoff.com · www.bollhoff-attexor.com